

TR-Electronic Safe Rotary Encoder Product Information CD_75

SIL3, PL_e

















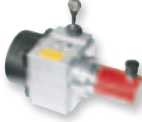



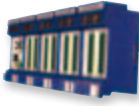

TR-Electronic – Your Partner in Automation

TR-Electronic can look back on more than 25 years of success, and is represented worldwide with an export share of more than 40 %. The core business comprises the development and manufacture of industrial angular and position measuring technology, as well as compact drive technology with integrated position control and measurement. The company is divided into three Business Units (BU) and is thus well positioned for further growth in the future.

Products in the **Rotary Encoder Business Unit** with optical or magnetic scanning precisely acquire position in steel production, wind power plants, cranes and ships as well as in explosion-proof versions in painting lines. Miniature versions ensure the correct position in medical technology. SIL3 approved absolute rotary encoders ensure the necessary safety.

In the **Linear Encoders Business Unit** magnetostrictive position sensors position injection molding machines, for example, or are directly integrated into hydraulic cylinders. Cascadable distance measurement sensors position parting units. With their high precision, glass scales on machine tools ensure precise position. Laser sensors based on phase difference measuring techniques position aisle stackers in warehousing and materials handling technology.

In the **Drives Business Unit** angle sensors are combined with compact drives: no external electronics are required, position, speed and torque controllers, power electronics and absolute rotary encoders are compactly integrated into the drive and thus bring intelligence directly to the drive shaft via the field bus. Compact drives are used for diverse applications in the printing and packaging industry and on palletizers.

					
					
Rotary Encoder	Linear Encoder	Drives	Components	Engineering	Unidor
 Incremental Encoder  Absolute Encoder  Draw Wire Encoder	 Magnetostriction  Glass scale  TOF laser  Barcode Positioning	 Actuator  Positioning Drive  Processing Drive	 I/O Module  Controls  Industrial-PC	Automation Solutions  Retrofit 	Punching and forming Measurement and control systems  Sensors  Process monitoring tools 

The portfolio is supplemented by the affiliated **TRsystems** with customized controls, industrial PCs, hydraulic controls as well as control units and sensors for punching and forming.

An essential factor for the success of **TR-Electronic** are the now more than **300 employees** who actively help to shape the product portfolio with innovations and successfully implement customer projects. Through its commitment to the regional colleges, TR-Electronic supports the high quality training of young employees and thus guarantees the highest level of innovation and quality at its Trossingen location.

A high degree of vertical integration allows customer-specific requirements to be responded to very quickly. The constantly new requirements on the mechanical design of sensors, on innovative new operating interfaces and new plug connectors result in a rapidly increasing product diversity. With **TR-Electronic** you have a partner who can fulfil these requirements.

Content

General			
Functional safety – plant safety and personal security	3	SIL-rotary encoder (solid shaft) – CDV 75 M PROFIsafe (PROFINET)	8
Overview SIL3/PL e – definition	3	SIL-rotary encoder (hollow shaft) – CDH 75 M PROFIsafe (PROFINET)	9
Product overview – TR-Electronic - Your partner in automation	20/21	Communication and Preset with PROFIsafe	10
Distribution addresses – Germany/International	22/23	Parametrizing over PROFIsafe	11
		Safe position, safe speed over PROFIsafe	12
		Synchronization and shaft control over PROFIsafe	13
Double rotary encoder CD_75 M with solid and hollow shaft		Pin assignment – CD_75 M PROFIsafe over PROFIBUS	14
General description – technical data and advantages	4	Pin assignment – CD_75 M PROFIsafe over PROFINET	15
Application areas – CD_75M	4		
Rotary encoder, safe according to SIL3/PL e – PROFIsafe and 2 × SSI	5	2 × SSI with check sum	
		SIL rotary encoder (solid shaft) – CDV 75 M 2 × SSI	16
PROFIsafe over PROFIBUS/PROFINET		SIL rotary encoder (hollow shaft) – CDH 75 M 2 × SSI	17
SIL-rotary encoder (solid shaft) – CDV 75 M PROFIsafe (PROFIBUS)	6	Safety according to SIL 3/PL e – SSI	18
SIL-rotary encoder (hollow shaft) – CDH 75 M PROFIsafe (PROFIBUS)	7	Pin assignment – CD_75 M 2 × SSI	19

Functional safety – plant safety and personal security

For a lot of applications in automation technology, there are high safety requirements. Dangerous plant conditions can be avoided by using SIL3/PL e certified rotary encoders. You don't have to separately prove the functional safety of these position sensors.

Current solution

Until now, for applications with high safety requirements, absolute rotary encoders with additional incremental signals have been used. The incremental signals function as a control over the positioning values. With this method, there was a safety deficit when turning on the machine, because there was only one absolute value available.

If this value was wrong due to data loss or an adjustment value, it couldn't be detected.

Certified solution

The absolute rotary encoder CD_75 M captures the revolution information through a mechanical gear without a battery backed revolution counter. Development, technology and production of this device is certified through the TÜV*. They are used in plants and equipment requiring safety integrity level 3 (SIL3: IEC 61508/EN 62061) or a performance level e (PL e: EN ISO 13849 -1). The CD_75 PROFIsafe additionally gives out safe speed values.

*German Association for Technical Inspection

Advantage of certified components

The basic safety norm IEC 61508 differentiates between measures to eliminate errors and measures to control errors. The measures to eliminate errors embrace the entire design and development process. These are required for the development of individual components and they serve to avoid systematic errors. Important for error control are quantifiable characteristics of the considered components and of the complete system. Priority has the probability of a dangerous failure of the safety function. The calculation results of the rated failure probability of all individual components for the entire safety chain.

It is checked and documented how systematic errors can be avoided or controlled for certified components. If not certified components are chosen to be used solely based on their mathematical safety value the responsibility is laid upon the person who made the construction. The producer of components with certification makes a clear statement: "Yes, ideal for safety oriented applications." As a user of certified components you can rely on this – after all the certification according to SIL3 or PL e has been given by independent specialists.

SIL and PL - two scales for safety

SIL The safety integrity level (SIL) is described in the international norm according to IEC 61508. It serves to judge electrical/programmable systems relying on dependability of safety functions. The aimed-at level indicates which safety-related construction principals have to be satisfied to minimize the risk of malfunctions.

PL Within the norm EN ISO 13849-1 five categories are defined called performance levels (PL). They are building up on each other starting with a, b, c, d and e. The different levels help to classify safety-related performances. They are determined out of the average probability value of a dangerous failure and the diagnostic coverage and considering the structural construction of a system (how many channels has the system, how independent are they from each other). Our safety rotary encoders are certified according to PL "e" the highest performance level.

Safety rotary encoder with PROFIsafe or 2 SSI interfaces

The double rotary encoder system with hollow shaft and multi turn detection fulfills the requirement of EN 61508¹. The use of certified individual components makes it easier for the system integrator to fulfill safety requirements of the entire application, for example within the event technology and storage and logistic technology. The use of our SIL3 certified safety absolute rotary encoder liberates the user from the obligation to prove functional safety for this positioning sensor separately. With certified components the strict safety guidelines will be achieved. The double rotary encoders CD_75 M are

available with hollow and solid shaft. They are approved for applications according to SIL3 or PL e.



SIL3, PL e

For local motor feedback, there is an optional rectangle or sine/cosine incremental output available. Different resolutions can be chosen (period/revolution).

Possible application areas:

- _crane technology
- _event and stage technology
- _drive technology
- _conveying systems and logistics
- _machinery and plant engineering
- _automation technology
- _wind energy plant

Cranes with overlapping work areas or with obstacles within the working area – through measurement of rope positions and rotation angles, collisions can be avoided.









Numerous travelling cranes on a common track – through safe measurement of each position, collision can be avoided.

Common work areas of men and machines – through safe position detection the various areas of safety, parameters can be differentiated from each other.

Processes with minimal or maximum speed – through safe speed sensing (PROFIsafe over PROFIBUS) it is assured that the drive never oversteps a maximum speed or that it safely achieves a required speed, before starting a process.

Synchronous run monitoring² – a not safe electrical axial synchronization can be made safe by using a certified SIL3/PL e rotary encoder with an external attached safety system.

Shaft control² – rotation through overload or a twist-off will be detected through a SIL3/PL e rotary encoder with an external safety system.

PROFIsafe over 		PROFIsafe over 		2 x SSI with checksum	
Solid shaft	Hollow shaft	Solid shaft	Hollow shaft	Solid shaft	Hollow shaft
CDV 75 M PROFIsafe	CDH 75 M PROFIsafe	CDV 75 M PROFIsafe	CDH 75 M PROFIsafe	CDV 75 M SSI	CDH 75 M SSI
					
resolution 13 bit x 32.768 revolutions				resolution 13 bit x 4.096 revolutions in system 1 13 bit x 4.096 revolutions in system 2	
flange/shaft combination, e.g. centering collar 50 mm/36 mm,	20 mm with groove	Flansch-/Wellen-Kombinationen, z.B. Zentrierbund 50 mm/36 mm, Welle mit Nut	20 mm mit Nut	flange/shaft combination, e.g. centering collar 50 mm/36 mm, shaft with groove	20 mm with groove
shaft with groove				-	
<p>Your configuration possibilities: additional incremental signals, resolution is factory provided, optional rectangle 5 V 1.024, 2.048, 4.096, 8.192, 16.384, 32.768 impulses/revolution or sine/cosine 1Vss 1.024, 4.096 periods/revolution</p>					

¹test regulations category 4/PL e according to EN ISO 13849-1, SIL CL3 according to EN 61800-5-2/EN 62061 and IEC 61508. ²on request

Rotary encoder, safe according to SIL 3/PL e

Within the revolution in system 1 the shaft position is detected with an optical single turn encoder. The revolutions are detected over mechanically attached satellites. This gives the absolute positioning value of measurement system one. For system two, the revolution position is transferred on a magnetic central detection, the revolutions are detected with magnetic equipped satellites. This gives the absolute

positioning value of measurement system two. The CPUs give each other signs of life.

The optical detection gives out incremental signals. It can be chosen between rectangle and sine/cosine outputs with various resolutions. For safety reasons, the resolutions of the measurement systems are not programmable.

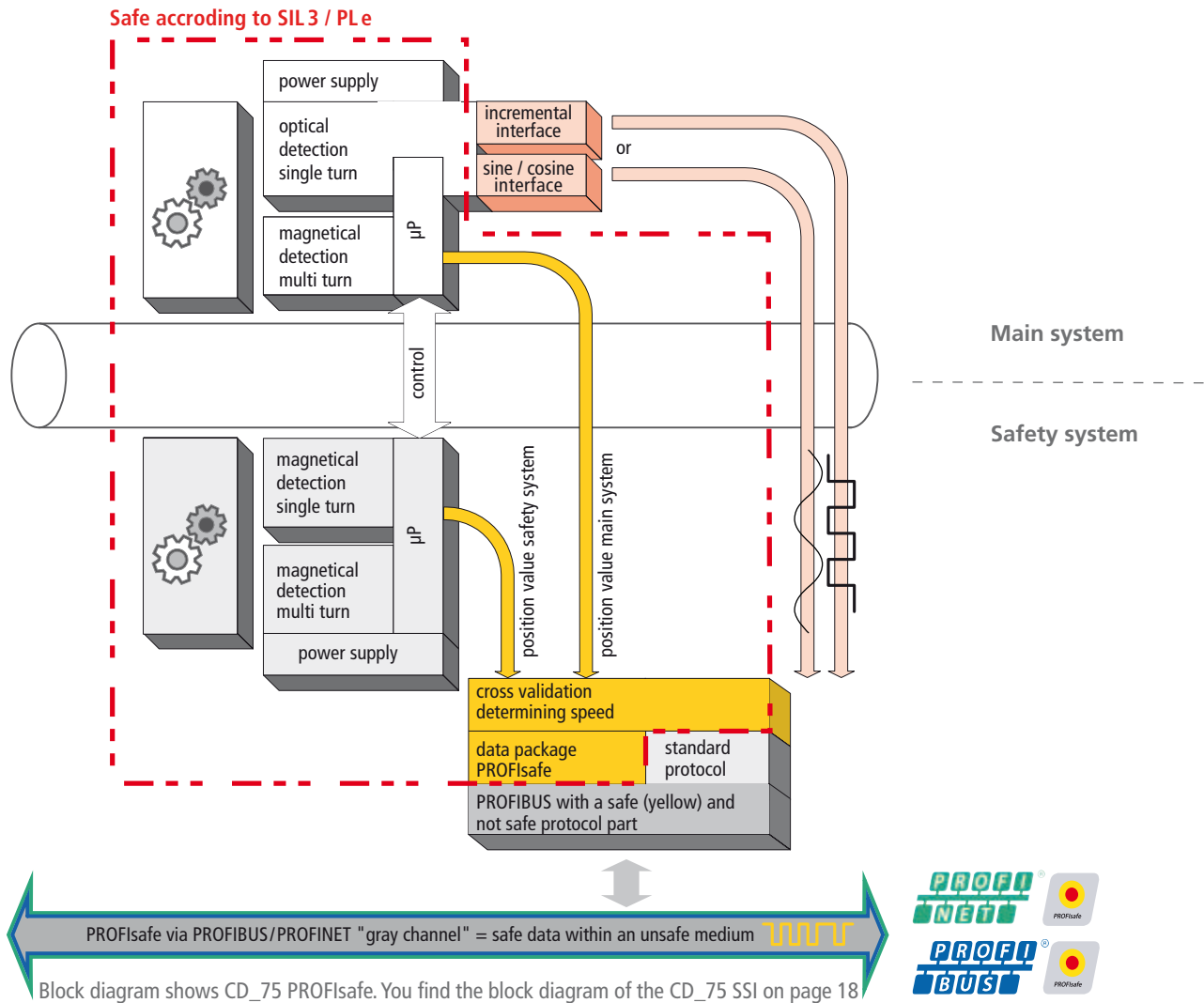

Block diagram shows CD_75 PROFIsafe. You find the block diagram of the CD_75 SSI on page 18

Certification, PROFIBUS

SIL CL 3 according to IEC 61508 PL e according to EN ISO 13849-1

PROFIBUS/PROFIsafe: certified has been the PROFIBUS activation (PI certificate Z01522), the PROFIsafe conformance (PI certificate Z20031) as well as the fulfillment of the safety standards (TÜV Rheinland, 01/205/5015/10).



Certification, PROFINET

SIL CL 3 according to IEC 61508 PL e according to EN 61800-5-2

PROFINET/PROFIsafe: certified has been the PROFINET (PI certificate Z10472), the PROFIsafe conformance (PI-Zertifikat Z20068) as well as the fulfillment of the safety standards (TÜV Rheinland, 01/205/5221/12).



SIL rotary encoder with solid shaft and PROFIsafe via PROFIBUS

- + PROFIBUS interface with PROFIsafe protocol
- + design with solid shaft
- + functional safety according to
DIN EN 61508: SIL 3
EN ISO 13849-1: PL e
- + 13 bit resolution, 32.768 revolutions
- + sine/cosine signals or incremental signals for position feedback

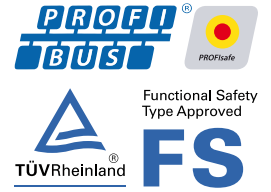

Electrical data

Voltage supply	11 ... 27 V DC
Current consumption at no-load	< 150 mA, at 24 V DC

Main measurement system

Capacitance	28 bit
Steps / revolution	8.192
Revolutions	32.768

Safety system

	2 redundant scanning systems with internal cross validation. Adjustable window of difference. Safety system optional external connected (cf. page 13).
--	--

Capacitance	The data of the internal safety system will not be separately issued.
Steps / revolution	
Revolutions	

Safety standard

Safety Integrity Level (SIL)	SIL 3 (DIN EN 61508)
Performance Level (PL)	PL e (EN ISO 13849)
PFH, complete system	$8,45 \times 10^{-10}$ 1/h

Mechanical data

Mechanically permissible speed	$\leq 6.000 \text{ min}^{-1}$
Shaft load (end of the shaft)	$\leq 50 \text{ N}$ axial, $\leq 90 \text{ N}$ radial
Bearing life time	$\geq 3,9 \times 10^{10}$ revolutions
- at speed	$\leq 3.000 \text{ min}^{-1}$
- at operating temperature	$\leq 60 \text{ }^\circ\text{C}$
Permissible angular acceleration	$\leq 10^4 \text{ rad/s}^2$
Mass (typical)	1 kg

Environmental conditions

Protection class DIN EN 60529	IP 54
Working temperature	-20 °C ... +70 °C
Relative humidity, DIN EN 60068-3-4	98 %, non condensing
Storage temperature	-30 °C ... +80 °C, dry
Vibration, DIN EN 60068-2-6	$\leq 100 \text{ m/s}^2$, sine 50–2.000 Hz
Shock DIN EN 60068-2-27	$\leq 1.000 \text{ m/s}^2$, half-sine, 11 ms
Emitted interference	class B, industrial areas

Interface

Protocol	PROFIBUS
Transferred values	safe position, safe speed (PROFIsafe); position, speed (PROFIBUS)
Programmable parameter	integration time, window of difference, direction of rotation, preset
Unsafe incremental interface	A, A-, B, B-
Number of pulses (fixed)	sine/cosine (1 Vss): 1.024 or 4.096
or	
Number of pulses (fixed)	rectangle (RS 422): 1.024, 2.048, 4.096, 8.192, 16.384 or 32.768

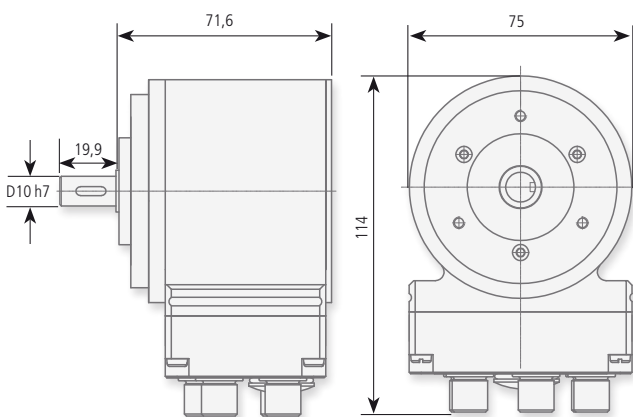

Please ask for detailed drawings.

Order information:

Order number	CDV75M-00002
Flange / shaft	centering collar 50 h7 shaft 10 h7 with groove 3 N9 × 10,2
Unsafe incremental track	Rectangle (RS 422) 4.096 steps/revolution. Further on request.

SIL rotary encoder with hollow shaft and PROFIsafe via PROFIBUS

- + PROFIBUS interface with PROFIsafe protocol
- + design with hollow shaft (max. 20 mm shaft diameter)
- + functional safety according to
DIN EN 61508: SIL 3
EN ISO 13849-1: PL e
- + 13 bit resolution, 32.768 revolutions
- + sine/cosine signals or incremental signals for position feedback

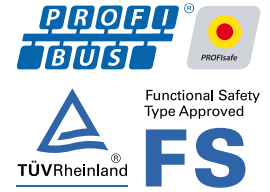

Electrical data

Voltage supply	11 ... 27 V DC
Current consumption at no-load	< 150 mA, at 24 V DC

Main measurement system

Capacitance	28 bit
Steps/revolution	8.192
Revolutions	32.768

Safety system

	2 redundant scanning systems with internal cross validation. Adjustable difference. Safety system optional external connected (cf. page 13).
--	--

Capacitance	The data of the internal safety system will not be separately issued.
Steps/revolution	
Revolutions	

Safety standard

Safety Integrity Level (SIL)	SIL 3 (DIN EN 61508)
Performance Level (PL)	PL e (EN ISO 13849)
PFH, complete system	$8,45 \times 10^{-10}$ 1/h

Mechanical data

Mechanically permissible speed	$\leq 3.000 \text{ min}^{-1}$
Shaft load (end of the shaft)	dead weight of the rotary encoder
Bearing life time	$\geq 3,9 \times 10^{10}$ revolutions
- at speed	$\leq 1.500 \text{ min}^{-1}$
- at operating temperature	$\leq 60 \text{ }^\circ\text{C}$
Permissible angular acceleration	$\leq 10^4 \text{ rad/s}^2$
Mass (typical)	1 kg

Environmental conditions

Protection class DIN EN 60529	IP 54
Working temperature	-20 °C ... +70 °C
Relative humidity, DIN EN 60068-3-4	98 %, non condensing
Storage temperature	-30 °C ... +80 °C, dry
Vibration, DIN EN 60068-2-6	$\leq 100 \text{ m/s}^2$, sine 50–2.000 Hz
Shock DIN EN 60068-2-27	$\leq 1.000 \text{ m/s}^2$, half-sine, 11 ms
Emitted interference	Class B, industrial areas

Interface

Protocol	PROFIBUS
Transferred values	PROFIsafe Safe position, safe speed (PROFIsafe); Position, speed (PROFIBUS)
Programmable parameter	integration time, window of difference, direction of rotation, preset
Unsafe incremental interface	A, A-, B, B-
Number of pulses (fixed)	sine/cosine (1 Vss): 1.024 or 4.096 or rectangle (RS 422): 1.024, 2.048, 4.096, 8.192, 16.384 or 32.768

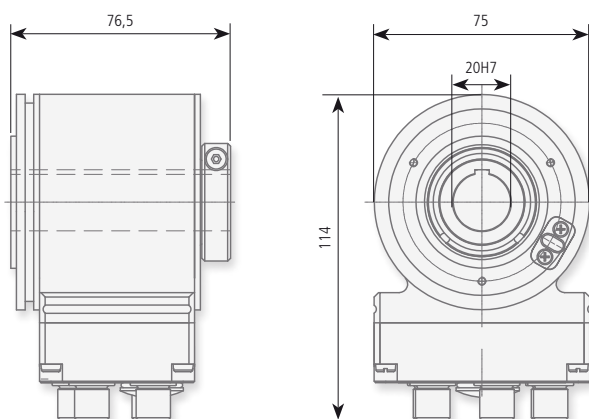

Please ask for detailed drawings.

Order information:

Order number	CDH75M-00008
Flange / shaft	hollow shaft 20 H7 with nut 5 J59; flange sided attachment for rotation prevention
Unsafe incremental track	Rectangle (RS 422) 32.768 steps/revolution. Further on request.

SIL-rotary encoder with solid shaft over PROFINET

- + PROFINET interface with PROFIsafe protocol
- + design with solid shaft
- + functional safety according to
 - DIN EN 61508: SIL 3
 - EN ISO 13849-1: PL e
- + 13 bit resolution, 32.768 revolutions
- + sine/cosine signals or incremental signals for position feedback



Electrical data

Voltage supply	13 ... 27 V DC, SELV/PELV
Current consumption at no-load	< 180 mA, at 24 V DC

Main measurement system

Capacitance	28 bit
Steps/revolution	8.192
Revolutions	32.768
Safety principle	2 redundant scanning systems with internal cross validation.

Parameter¹⁾

- Integration time, safe/unsafe	50 ... 500 ms/5 ... 500 ms
- Size of monitoring window	50 ... 4.000 increments
- Standstill tolerance Preset	1 ... 5 increments / integration time, safe
- Direction of counting	Forward, Backward
Output code	binary
Cycle time	≥ 1 ms (IRT/RT)
Transmission rate	100 MBit/s
TR specific functions ¹⁾	velocity output in increments / integration time, safe

Mechanical data

Mechanically permissible speed	≤ 6.000 min ⁻¹
Shaft load (end of the shaft)	≤ 50 N axial, ≤ 90 N radial
Bearing life time	≥ 3,9 × 10 ¹⁰ revolutions
- at speed	≤ 3.000 min ⁻¹
- at operating temperature	≤ 60 °C
Permissible angular acceleration	≤ 10 ⁴ rad/s ²
Start-up torque at 20 °C	typically 0,6 Ncm
Mass (typical)	1 kg

Environmental conditions

Protection class DIN EN 60529 ²⁾	IP 54
Working temperature	0 °C ... +60 °C
Relative humidity, DIN EN 60068-3-4	98 %, non condensing
Storage temperature	-30 °C ... +80 °C, dry
Vibration DIN EN 60068-2-6	≤ 100 m/s ² , Sinus 50–2.000 Hz
Shock DIN EN 60068-2-27	≤ 600 m/s ² , half-sine, 5 ms

EMC

- Immunity to disturbance	EN 61000-6-2
- Transient emissions	EN 61000-6-3

Interface

Protocol	PROFINET
Incremental output without zero impulse	-
- Or Sin/Cos-output	-
- Number of pulses, factory setting	4.096, 8.192, 12.288, 16.384, 20.480
PROFINET IO - Device	IEC 61158, IEC 61784-1; PROFIsafe-profile: No. 3.192b
Additional features	Preset

Safety of the total system

PFH, „High demand“ mode	1.45 × 10 ⁻⁹ 1/h
PFD _{av} (T = 15 a)	9.53 × 10 ⁻⁵
MTTF _d high	421 a
DC _{avg} high	95 %

¹⁾secured programmable parameter ²⁾valid with screwed on mating connector and /or screwed together cable gland

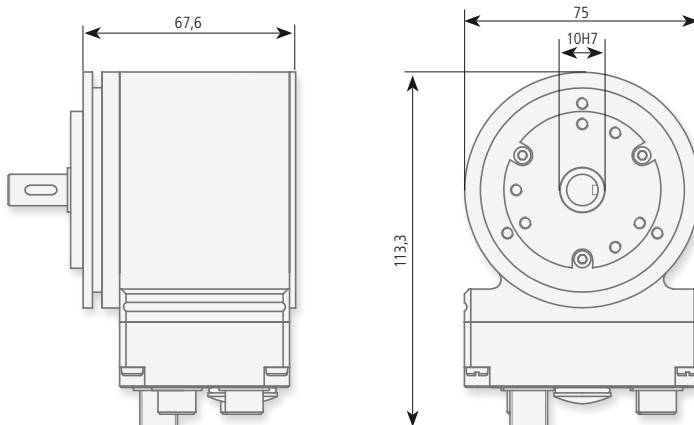

Order information:

Order number	CDV75M-00012
Flange/shaft	centering collar 50 h7 shaft 10 h7 with groove 3 N9 × 10,2
Unsafe incremental track	Rectangle (RS 422) 4.096 steps/revolution. Further on request.

Please ask for detailed drawings.

SIL-rotary encoder with hollow shaft over PROFINET

- + PROFINET interface with PROFIsafe protocol
- + design with hollow shaft (max. 20 mm shaft diameter)
- + functional safety according to
DIN EN 61508: SIL 3
EN ISO 13849-1: PL e
- + 13 bit resolution, 32.768 revolutions
- + sine/cosine signals or incremental signals for position feedback



Electrical data

Voltage supply	13 ... 27 V DC, SELV/PELV
Current consumption at no-load	< 180 mA, at 24 V DC

Main measurement system

Capacitance	28 bit
Steps / revolution	8.192
Revolutions	32.768
Safety principle	2 redundant scanning systems with internal cross validation.

Parameter¹

- Integration time, safe / unsafe	50 ... 500 ms / 5 ... 500 ms
- Size of monitoring window	50 ... 4.000 increments
- Standstill tolerance Preset	1 ... 5 increments / integration time, safe
- Direction of counting	Forward, Backward
Output code	binary
Cycle time	≥ 1 ms (IRT / RT)
Transmission rate	100 MBit/s
TR specific functions ¹	velocity output in increments / integration time, safe

Mechanical data

Mechanically permissible speed	≤ 3.000 min ⁻¹
Shaft load	Own mass
Bearing life time	≥ 3,9 × 10 ¹⁰ revolutions
- at speed	≤ 1.500 min ⁻¹
- at operating temperature	≤ 60 °C
Permissible angular acceleration	≤ 10 ⁴ rad/s ²
Start-up torque at 20 °C	typically 6 Ncm
Mass (typical)	1 kg

Environmental conditions

Protection class DIN EN 60529	IP 54
Working temperature	0 °C ... +60 °C
- optionally	-20 °C ... +70 °C
Relative humidity, DIN EN 600068-3-4	98 %, non condensing
Storage temperature	-30 °C ... +80 °C, dry
Vibration DIN EN 60068-2-6	≤ 100 m/s ² , Sinus 50–2.000 Hz
Shock DIN EN 60068-2-27	≤ 600 m/s ² , half-sine, 5 ms
EMC	
- Immunity to disturbance	EN 61000-6-2
- Transient emissions	EN 61000-6-3

Interface

Protocol	PROFINET
Incremental output without zero impulse	-
- Or: Sin / Cos-output	
- Number of pulses, factory setting	4.096, 8.192, 12.288, 16.384, 20.480
PROFINET IO - Device	IEC 61158, IEC 61784-1; PROFIsafe-profile: No. 3.192b
Additional features	Preset

Safety of the total system

PFH, „High demand“ mode	1.45 × 10 ⁻⁹ 1/h
PFD _{av} (T = 15 a)	9.53 × 10 ⁻⁵
MTTF _d high	421 a
DC _{avg} high	95 %

¹secured programmable parameter ²valid with screwed on mating connector and / or screwed together cable gland

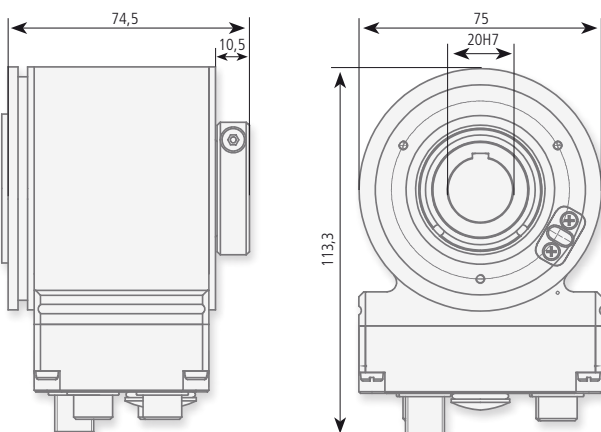

Order information:

Order number	CDH75M-00010
Flange / shaft	hollow shaft 20 H7 with nut 5 JS9; flange sided attachment for rotation prevention
Unsafe incremental track	Rectangle (RS 422) 32.768 steps/revolution. Further on request.

Please ask for detailed drawings.

Communication with PROFIsafe via PROFIBUS/PROFINET

The actual values will be transferred over PROFIsafe. Within the safe protocol part the actual value and the speed will be transferred. These values are also available over not safe normal PROFIBUS/PROFINET telegrams. Therefore, safe and normal control parts have access to it. Certified are the PROFIBUS/PROFINET activation, the PROFIsafe compliance, as well as the fulfilling of the safety standards (Further information you will find on page 5).

The actual values for position and speed are transferred in two slots:

For safe transmission the actual position values of both rotary encoder systems are compared. If the difference is smaller than the adjusted control window, the rotary encoder value does count as safe. The safe actual position value and the hence calculated safe speed value will be transferred over the PROFIsafe telegram.

The part of the control taking on the safety related tasks can process these values.

The actual position value and the calculated speed of the main rotary encoder are directly transferred within the not safe process data channel. Usually, this channel is processed more often by the controller. Normal automation processes can access more often actual position values.

PROFIBUS/PROFINET protocol

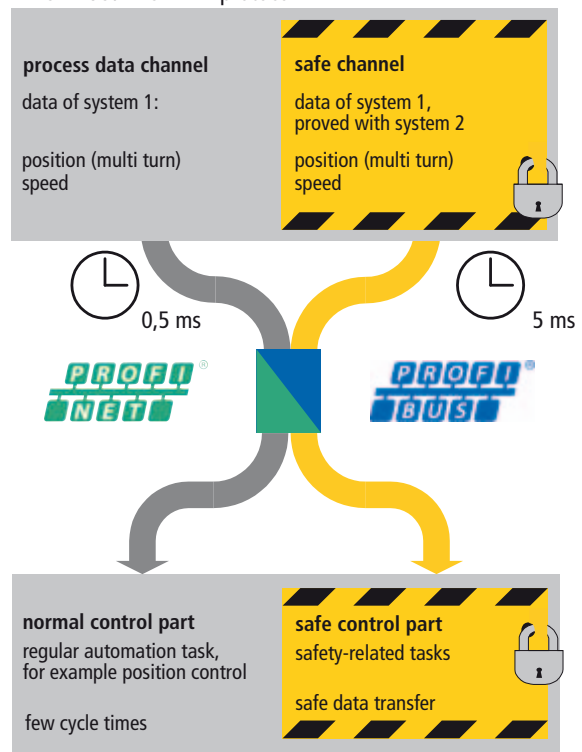

Preset over PROFIsafe

By setting a preset value, the actual issued value of the rotary encoder can be placed arbitrarily at a value within the maximum measurement range. With this, the shown position can be placed electronically at a machine referencing position. The offset value will be saved within the rotary encoder.

Setting a preset value is a safety-relevant process. An arising jump of the actual value, for example using a controller, can lead to an uncontrolled movement of the machine. Therefore, setting a preset value can only be done when the concerning machine part is standing still. The preset is already locked within the rotary encoder and can solely be activated over a special part within the safe protocol part.

Even if all preconditions of the controller are fulfilled, the preset will only be executed when the rotary encoder shaft stands still. Further measures have to be taken in account. The controller can start the preset process only when the related drives are locked against running. It is recommended, to lock the preset process from the controller through further safety measurements (for example key switches, password prompts, ...).

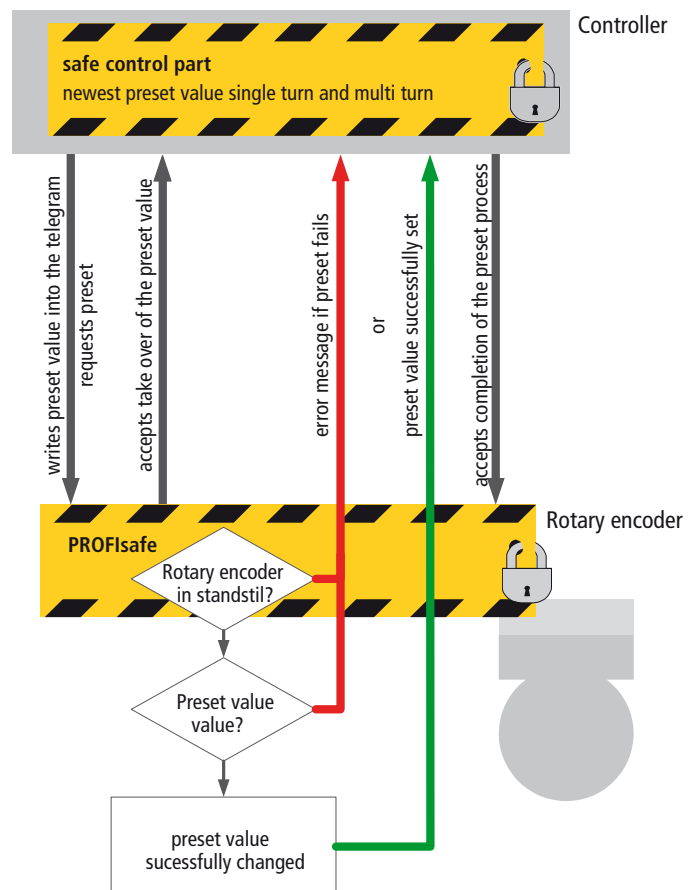



Parameterization via PROFIsafe

Parameters are transferred each time over the bus when the machine runs up. The set of parameters will be saved over a checksum.

Window of difference

Permissible difference between the rotary encoder values of system 1 and system 2.

Window of standstill

To trigger a preset process (see page 8), the rotary encoder must stand still. Depending on the drive, it is necessary to specify its tolerance range.

Direction of rotation

Positive count direction clockwise/counterclockwise.

Integration time

Time base of the speed calculation. High integration times enable high resolution measurements at a low rotary speed. A small integration time shows speed changes faster: well suited for high rotation speeds and great dynamics. Information is multiple of the cycle time of the rotary encoder system. For process data channel (not safe) 5 ... 500 ms, for safe channel 50 ... 500 ms.

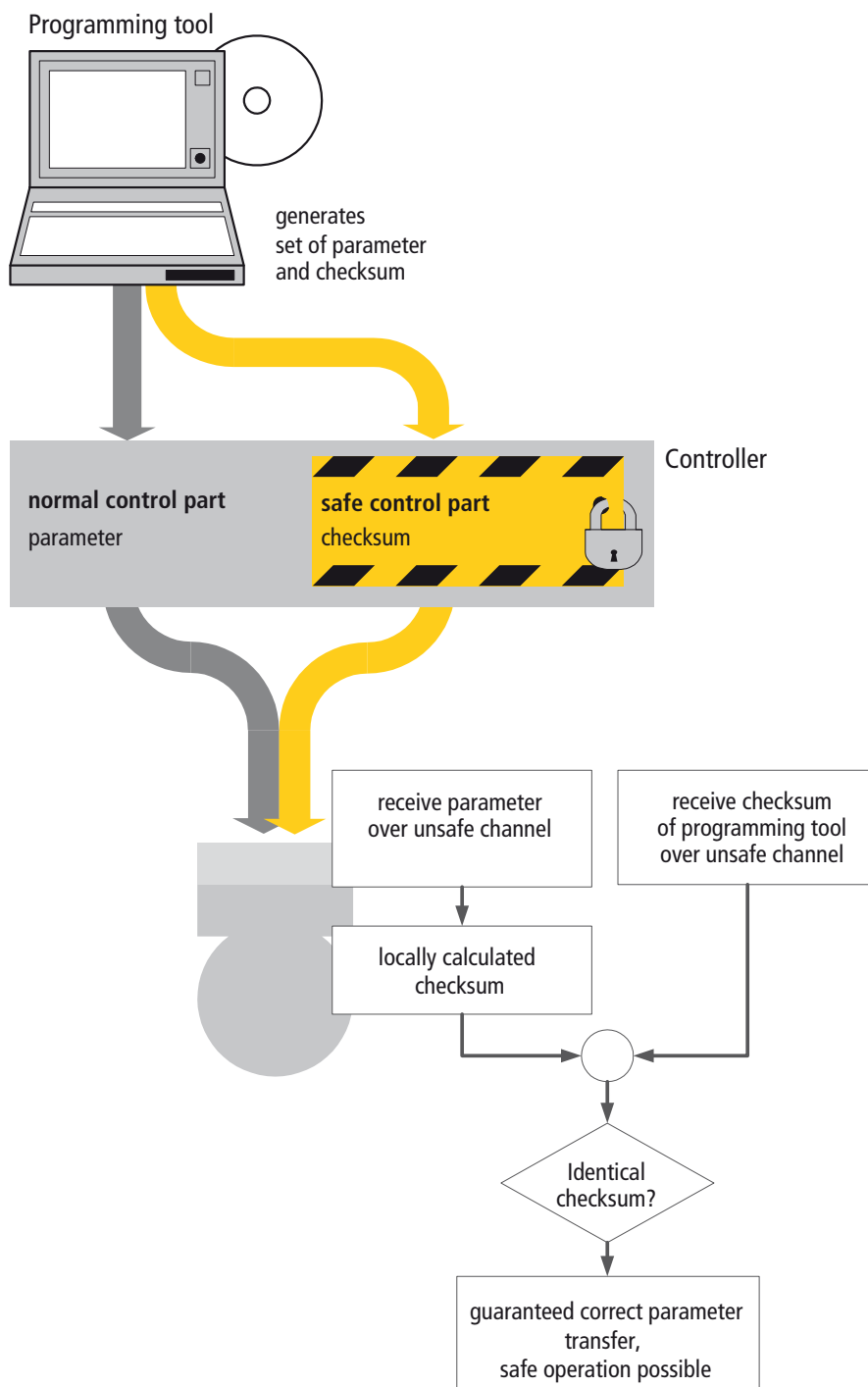

Integrated Safety – CD_75M

For numerous industrial applications such as presses, cranes and robots, it is important to exactly capture the movement in position and speed. These movements could permanently be accompanied by a hazard. Therefore, working stations, positions and speed are always controlled.

In general, controls like this require a higher standard in technology. The according functions are interpreted as safety functions with necessary SIL / PL. For positioning sensors, the following ways of secured data are possible.

Secured Speed Data

Secured speed data is needed, to allow access to a usually dangerous area where such as maintenance or start-up work has to be done. The CD_75M delivers a safe position information which is used in a controller to realize a secured maximum speed (SLS: Safely Limited Speed).

Safe Position

A safety function needs reliable position information, when in different areas different safety requirements should be determined. With this information for example a "Safe Direction – SDI" can be realized or other safety parameters in dependence of the position can be determined. Der CD_75M sends the safe position information directly over PROFIBUS respectively PROFINET or safely over PROFIsafe protocol within the safety control.

Your Advantages:

- ✓ integrated safety
- ✓ no additional external SIL evaluation
- ✓ no additional expenditures in further sensors
- ✓ no extra time for installation and cabling of external SIL evaluations
- ✓ no additional integration into the controller

Conventional Standard versus Integrated Safety

Conventional Standard

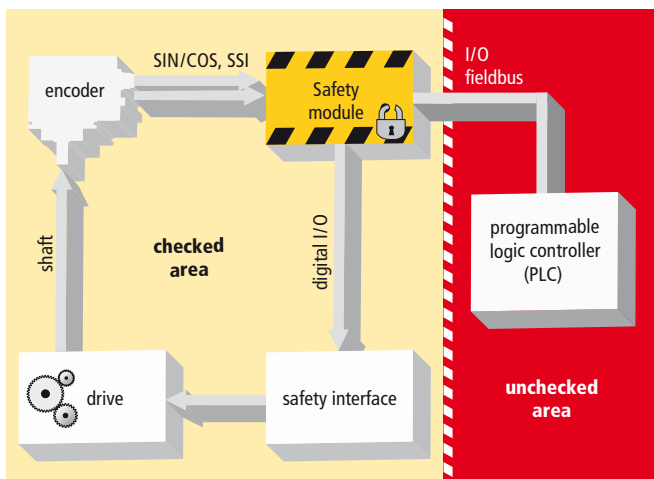

The tests of the signals are done in a safety module. Depending on the features of the rotary encoder, the safety module can identify the safe speed or single / multi turn position.

The safety module decides based on the parameters of limited values and functions whether the status of the machine is safe or the drive keeps running or has to stop. The safety function solely is restricted to this part of the plant. Are real positioning and speed values requested (e.g. controller), a second rotary encoder is needed. Both, the controller as well as the safety module have to be correctly programmed and parameterized.

For individual plant parts, this technology can be retrofitted. The rotary encoders used don't have to be certified. They only have to fulfill the requirements of the producer of the safety modules.

Integrated Safety – CD_75M

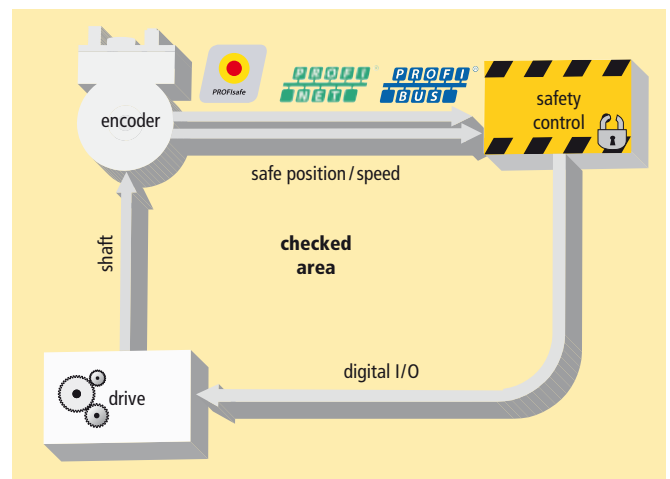

The measurement values of safe speed and safe multi turn position are determined within the certified rotary encoder. They are transmitted over a safe bus system to an equally certified safety module. Therefore, the safe sensor values are available for each controller of the entire machine or plant.

This enables intelligent safety concepts where humans and machines share the work environment without mechanical safety devices. Work areas can be divided into different zones with adjusted safety requirements.

Position and speed values are available for either safety applications over a secured channel as well as for normal automation functions over a not secured channel (see page 11). Therefore, a rotary encoder for position feedback is unnecessary. Due to the integration of the PLC a safe operation with a large range of functions can be guaranteed.

Monitoring of the synchronisation and the shaft*

Normally, the quality of the position value will be saved within the second rotary encoder system of the CD_75 M PROFIsafe. Alternatively, a CD_75 M SSI can be used. The actual values of both mechanically separated systems are compared with each other. If the difference between the positions is less than the adjusted window of difference, the position value counts as save.

Monitoring of the synchronization

The two rotary encoders CD_75 M PROFIsafe (primary system) and CD_75 M SSI (secondary system) will be mounted on the opposite of the drive train for example at a gantry crane. If the actual difference

between both systems is bigger than the allowed window of difference, it will be reported as an error and the superior control can react safely.

Monitoring of the shaft

The rotary encoder CD_75 M PROFIsafe (primary system) will be mounted on the drive and the CD_75 M SSI will be mounted at the drive side. With an incorrect rotation of the shaft (due to overload or fracture) the position values of both systems differ. If this value is outside the window of difference, it will be reported as an error and the superior control can react safely.

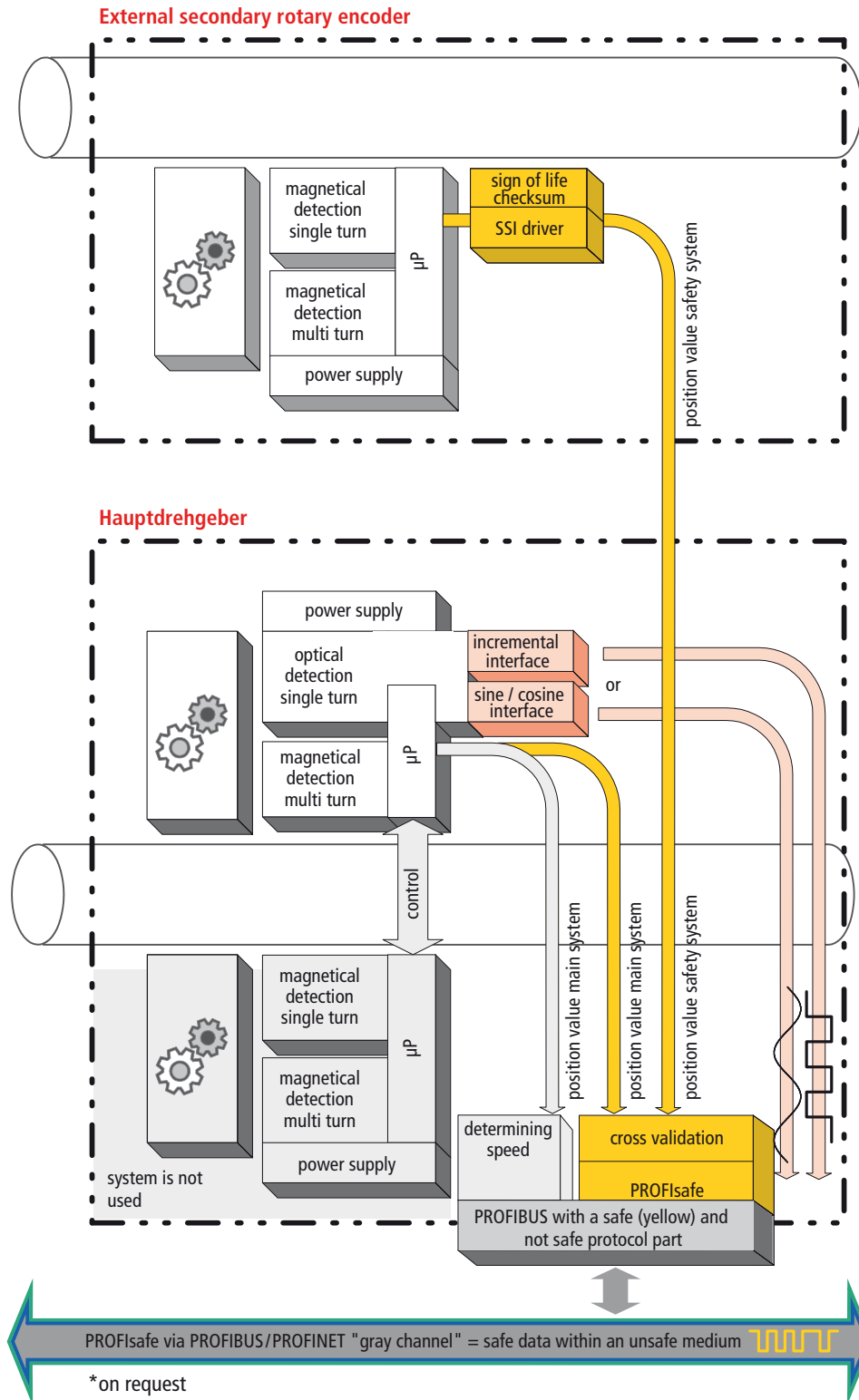

*on request



Pin assignment CD_75 M PROFIBUS with PROFIsafe protocol

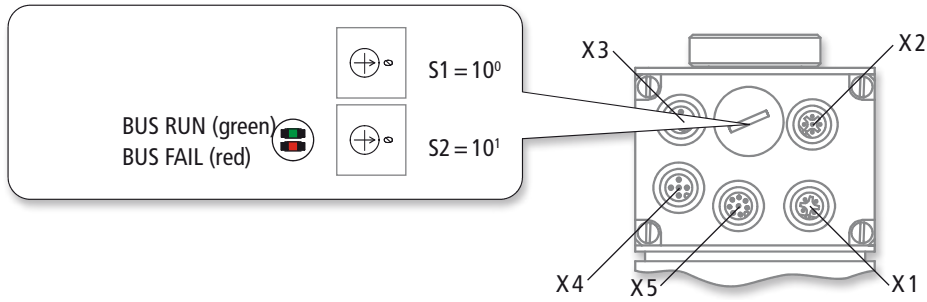

The shielding is to be connected with a large surface on the mating connector!

X 1, voltage supply

X 1	Pin (M 12 × 1-4 pol.)
1	+ 24 V DC
2	N.C.
3	0 V, GND
4	N.C.

A-coded

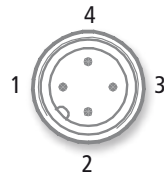

X 4, alternativ sine / cosine, differential

X 4	Connector (M 12 × 1-5 pol.)
1	Sine +, 1 Vss
2	Sine -, 1 Vss
3	Cosine +, 1 Vss
4	Cosine -, 1 Vss
5	0 V, GND

A-coded

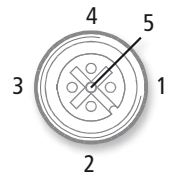

X 2, PROFIBUS IN

X 2	Pin (M 12 × 1-5 pol.)
1	N.C.
2	PROFIBUS, data A
3	N.C.
4	PROFIBUS, data B
5	N.C.

B-coded

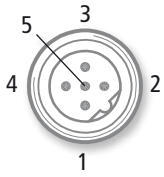

X 4, rectangle differential

X 4'	Connector (M 12 × 1-5 pol.)
1	Channel B +, 5 V
2	Channel B -, 5 V
3	Channel A +, 5 V
4	Channel A -, 5 V
5	0 V, GND

A-coded

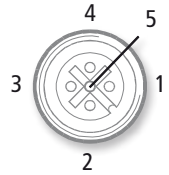

X 3, PROFIBUS OUT

X 3	Pin (M 12 × 1-5 pol.)
1	5 V, termination
2	PROFIBUS, data A
3	GND, termination
4	PROFIBUS, data B
5	N.C.

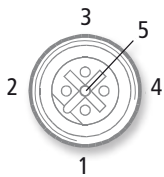

X 5, optional: SSI external safety channel

X 5	Connector (M 12 × 1-8 pol.)
1	SSI-Clock_OUT -
2	SSI-Clock_OUT +
3	SSI-Data_IN +
4	SSI-Data_IN -
5	NC
6	NC
7	+ 24 V DC_OUT
8	0 V, GND



If there is no further bus user, a PROFIBUS terminating resistor has to be plugged on. The terminating resistor is not included into the delivery and has to be ordered additionally.

PROFIBUS addresses

The PROFIBUS address has to be adjusted over the address switch S1 and S2 within the connection cap:

S1=10⁰, S2=10¹

Valid PROFIBUS addresses = 1- 99

PROFIBUS status LEDs

- ON
- OFF
- flashing
- 3 × 5 Hz

- BUS RUN:
 - ready for operation
 - missing supply, hardware error
 - invalied F_parameter
 - communication OK, reintegration requested

- BUS FAIL:
 - no error, bus within cycle
 - rotary encoder of the master is not
 - addressed safety relevant error, passivation

Pin assignment CD_75 M PROFINET with PROFIsafe protocol

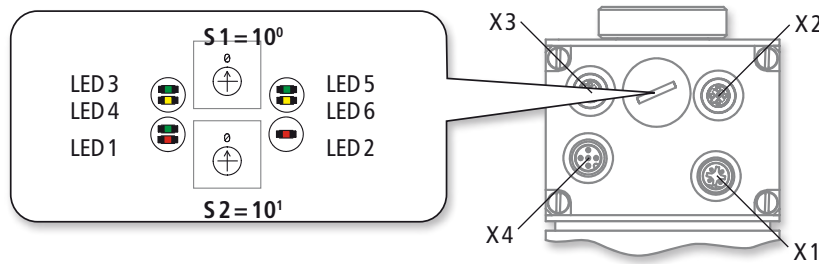

The shielding is to be connected with a large surface on the mating connector!

X1, voltage supply

X 1	Male Connector (M 12 × 1-4 pol.)
1	+ 24 V DC
2	N.C.
3	0 V, GND
4	N.C.

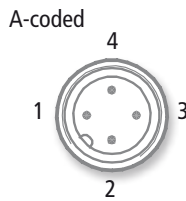

X4, alternativ SIN/COS, differential

X 4'	Female Connector (M 12 × 1-5 pol.)
1	Sine +, 1 Vss
2	Sine -, 1 Vss
3	Cosine +, 1 Vss
4	Cosine -, 1 Vss
5	0 V, GND

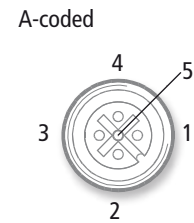

X2, PORT 2

X 2	Female Connector (M 12 × 1-4 pol.)
1	TxD +, Transmission Data +
2	RxD +, Receive Data +
3	TxD -, Transmission Data -
4	RxD -, Receive Data -

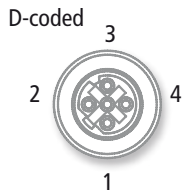

X4, incremental

X 4	Female Connector (M 12 × 1-5 pol.)
1	Channel B +, 5 V, differential
2	Channel B -, 5 V, differential
3	Channel A +, 5 V, differential
4	Channel A -, 5 V, differential
5	0 V, GND

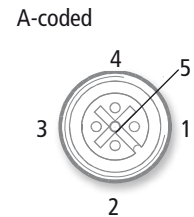

X3, PORT 1

X 3	Female Connector (M 12 × 1-4 pol.)
1	TxD +, Transmission Data +
2	RxD +, Receive Data +
3	TxD -, Transmission Data -
4	RxD -, Receive Data -

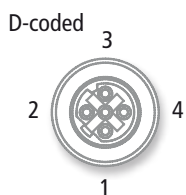

PROFINET-address

My means of the address switches S1 and S2 in the connection hood the PROFIsafe destination address is adjusted:

S1=10⁰, S2=10¹
Valid addresses = 1- 99

PROFINET LED Conditions

- on
- off
- flashing
- 3 × 5 Hz

- LED 1** bicolor, device status:
- ready for operation
 - missing supply, hardware error
 - re-integration required
 - System or safety relevant error

- LED 3 = Link, LED 4 = Data Activity**
- Ethernet connection established
 - Data transfer TxD/RxD

- LED 2** BUS Status:
- No error
 - Parameter- or F-Parameter error
 - No link to the IO-Controller

- LED 5 = Link, LED 6 = Data Activity**
- Ethernet connection established
 - Data transfer TxD/RxD

SIL rotary encoder with solid shaft and SSI interfaces

- + two redundant SSI interfaces
- + design with solid shaft
- + proved for the use in affiliation with SIL 3 safety functions
- + functional safety according to DIN EN 61508; VDE 0803: SIL 3 and EN ISO 13849-1: PL e
- + master system: 13 bit resolution, 4.096 revolutions, sine/ cosine - or incremental signals for position feedback
- + safety system: 13 bit resolution, 4.096 revolutions



SSI
SSI

Electrical data

Voltage supply	11 ... 27 V DC
Current consumption at no-load	< 150 mA, at 24 V DC

Main measurement system

Capacitance	25 bit
Steps / revolution	8.192
Revolutions	4.096

Safety system

2 redundant detection systems with separate output; mutual monitoring of μC ; via CRC and sign of life counter safed SSI protocol. The cross validation/safety analysis must happen within the controller.

Capacitance	25 bit
Steps / revolution	8.192
Revolutions	4.096

Safety standard

Safety Integrity Level (SIL)	SIL 3 DIN EN 61508 / VDE 0803
Performance Level (PL)	PL e EN ISO 13849
PFH, complete system	10×10^{-9} 1/h

Mechanical data

Mechanically permissible speed	$\leq 6.000 \text{ min}^{-1}$
Shaft load (end of the shaft)	$\leq 50 \text{ N}$ axial, $\leq 90 \text{ N}$ radial
Bearing life time	$\geq 3,9 \times 10^{10}$ revolutions
- at speed	$\leq 3.000 \text{ min}^{-1}$
- at operating temperature	$\leq 60 \text{ }^\circ\text{C}$
Permissible angular acceleration	$\leq 10^4 \text{ rad/s}^2$
Mass (typical)	1 kg

Environmental conditions

Protection class DIN EN 60529	IP 54
Working temperature	0 °C ... +60 °C
- optionally	-20 °C ... +70 °C
Relative humidity, DIN EN 60068-3-4	98 %, non condensing
Storage temperature	-30 °C ... +80 °C, dry
Vibration DIN EN 60068-2-6	$\leq 100 \text{ m/s}^2$, sine 50–2.000 Hz
Shock DIN EN 60068-2-27	$\leq 1.000 \text{ m/s}^2$, half-sine, 11 ms
Emitted interference	class B, industrial areas

Interfaces

Protocol	2 × SSI CRC-safed protocol with additional information
Transferred values	channel 1: position, error bit, sign of life counter, CRC channel 2: position, sign of life counter, status bits, CRC
Programmable parameter	-
Unsafe incremental interface	A, A-, B, B-
Number of pulses (fixed) or	sine / cosine (1 Vss): 1.024 or 4.096
Number of pulses (fixed)	rectangle (RS 422): 1.024, 2.048, 4.096, 8.192, 16.384 or 32.768
Code	binary

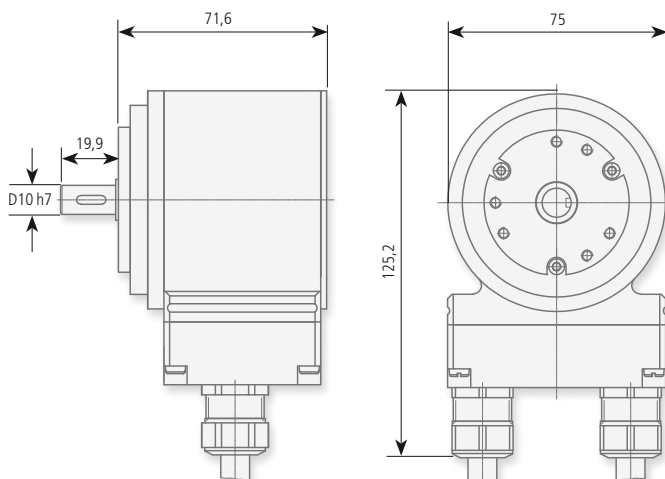

Order information:

Order number	CDV 75 M-00001
Flange / shaft	Centering collar 50 h7 shaft 10 h7 with groove 3 N9 × 10,2
Connection	2 cable glands, removable connection cap
Unsafe incremental track	Rectangle (RS 422) 4.096 steps/revolution, K1, K2 and inverse. Further on request.

Please ask for detailed drawings.

SIL rotary encoder with hollow shaft and SSI interfaces

- + two redundant SSI interfaces
- + design with hollow shaft, 20 mm shaft diameter
- + proved for the use in affiliation with SIL 3 safety functions
- + functional safety according to DIN EN 61508; VDE 0803: SIL 3 and EN ISO 13849-1: PL e
- + master system: 13 bit resolution, 4.096 revolutions, sine/ cosine - or incremental signals for position feedback
- + safety system: 13 bit resolution, 4.096 revolutions



SSI
SSI

Electrical data

Voltage supply	11 ... 27 V DC
Current consumption at no-load	< 150 mA, at 24 V DC

Main measurement system

Capacitance	25 bit
Steps/revolution	8.192
Revolutions	4.096

Safety system

2 redundant detection systems with separate output; mutual monitoring of μC ; via CRC and sign of life counter safed SSI protocol. The cross validation/safety analysis must happen within the controller.

Capacitance	25 bit
Steps/revolution	8.192
Revolutions	4.096

Safety standard

Safety Integrity Level (SIL)	SIL 3 DIN EN 61508/VDE 0803
Performance Level (PL)	PL e EN ISO 13849
PFH, Complete system	10×10^{-9} 1/h

Mechanical data

Mechanically permissible speed	$\leq 3.000 \text{ min}^{-1}$
Shaft load (end of the shaft)	dead weight of the rotary encoder
Bearing life time	$\geq 3,9 \times 10^{10}$ revolutions
- at speed	$\leq 1.500 \text{ min}^{-1}$
- at operating temperature	$\leq 60 \text{ }^\circ\text{C}$
Permissible angular acceleration	$\leq 10^4 \text{ rad/s}^2$
Mass (typical)	1 kg

Environmental conditions

Protection class DIN EN 60529	IP 54
Working temperature	0 °C ... +60 °C
- optionally	-20 °C ... +70 °C
Relative humidity, DIN EN 60068-3-4	98 %, non condensing
Storage temperature	-30 °C ... +80 °C, dry
Vibration DIN EN 60068-2-6	$\leq 100 \text{ m/s}^2$, sine 50–2.000 Hz
Shock DIN EN 60068-2-27	$\leq 1.000 \text{ m/s}^2$, half-sine, 11 ms
Emitted interference	class B, industrial areas

Interfaces

Protocol	2 × SSI CRC-safed protocol with additional information
Transferred values	channel 1: position, error bit, sign of life counter, CRC channel 2: position, sign of life counter, status bits, CRC
Programmable parameter	-
Unsafe incremental interface	A, A-, B, B-
Number of pulses (fixed) or	sine/cosine (1 Vss): 1.024 or 4.096
Number of pulses (fixed)	rectangle (RS 422): 1.024, 2.048, 4.096, 8.192, 16.384 or 32.768
Code	binary

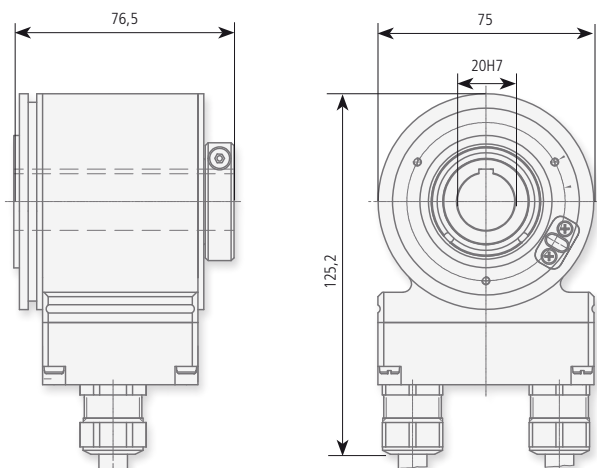

Please ask for detailed drawings.

Order information:

Order number	CDH75M-00001
Flange / shaft	hollow shaft 20 H7 with groove 5 JS9; flange sided attachment for rotation prevention
Connection	2 cable glands, removable connection cap
Unsafe incremental track	Rectangle (RS 422) 4.096 steps/revolution, K1, K2 and inverse. Further on request.

Safety according to SIL 3/PL e with 2 × SSI

The determined position values will be enhanced with status information and checksum. These position values will be distributed on separate SSI interfaces. It is the task of the sequential electronic, to determine the accuracy of the measurement values by comparing both values. Hereby, additional information within the SSI telegram is

helpful. The SSI telegram also transfers an error bit of the other system, therefore it is possible to diagnose that you have to look for an error within the rotary encoder (the other system reports the error) or in the cable (the other system reports no error).

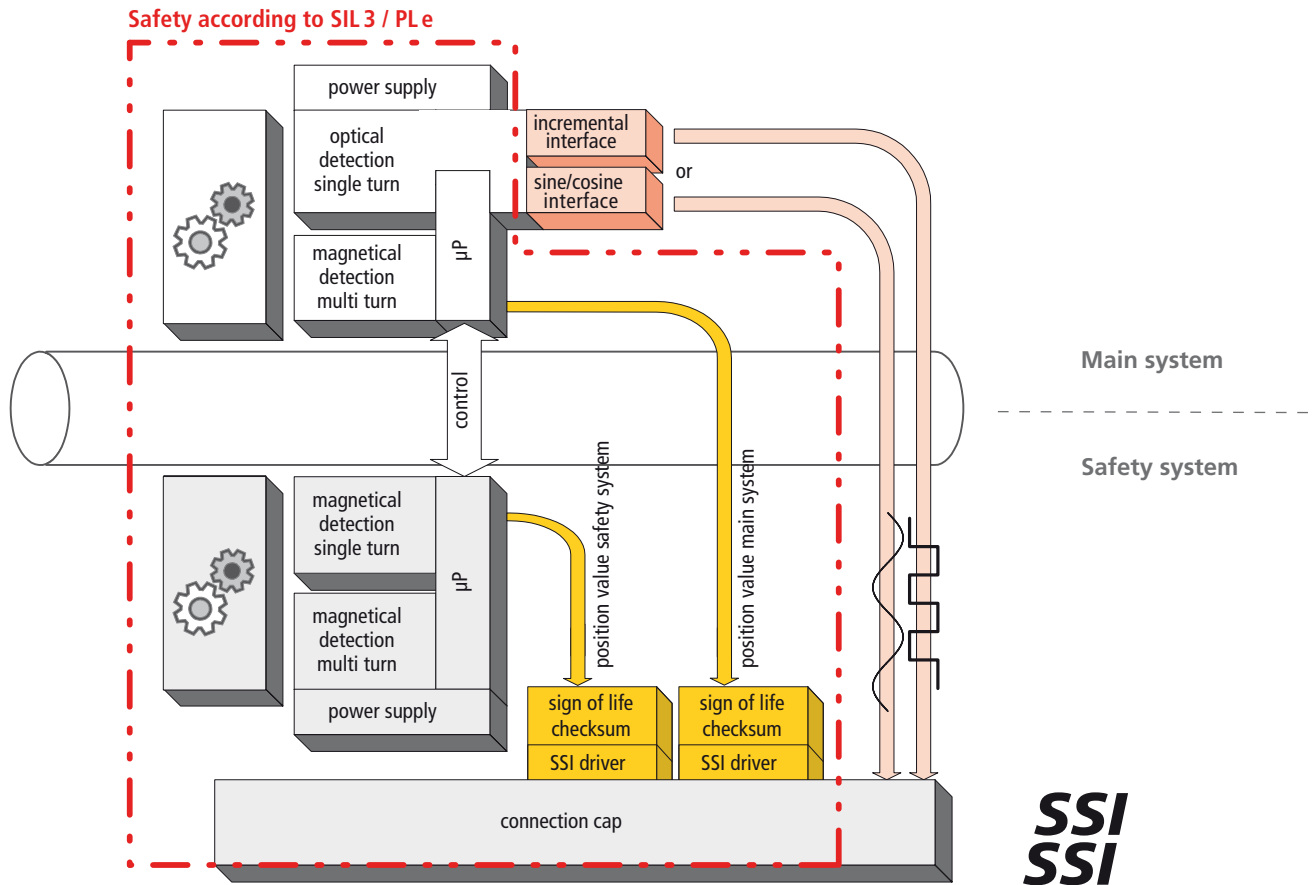

SSI telegramm (identical for main and safety system)

bit 0 ... 11	bit 12 ... 24	bit 25	bit 26	bit 27 ... 31	bit 32 ... 39
measurement value multi turn part	measurement value single turn part	own error bit	error bit of the other system	sign of life counter	checksum CRC
12 bit	13 bit	1 bit	1 bit	5 bit	8 bit

Both systems transfer the actual position value in an enhanced SSI telegram.

Error bit

The error bit of both systems is shown in both SSI channels. Therefore, if there is a difference in one of the SSI channels the error can be transferred into the other channel without doubt. Hence, the diagnosis of both systems can be realized when having one channel operation.

Checksum

An 8 bit CRC checksum will be calculated over all user data within the SSI telegram and then it will be put into the SSI telegram. Secured data: MT and ST data, error bits, sign of life counter. Hamming distance = 3: two incorrect data bits will safely be recognized.

Sign of life counter

The sign of life counter will be incremented with each detection process of the rotary encoder system. The incremented sign of life counter makes sure up to the latest telegram, that the actual transferred data comes out of a new position detection. If SSI requests happen faster than the internal detection (250 µs master channel, 500 µs safety channel), the position data and the sign of life counter are still unchanged.

Pin assignment CD_75 M 2 x SSI

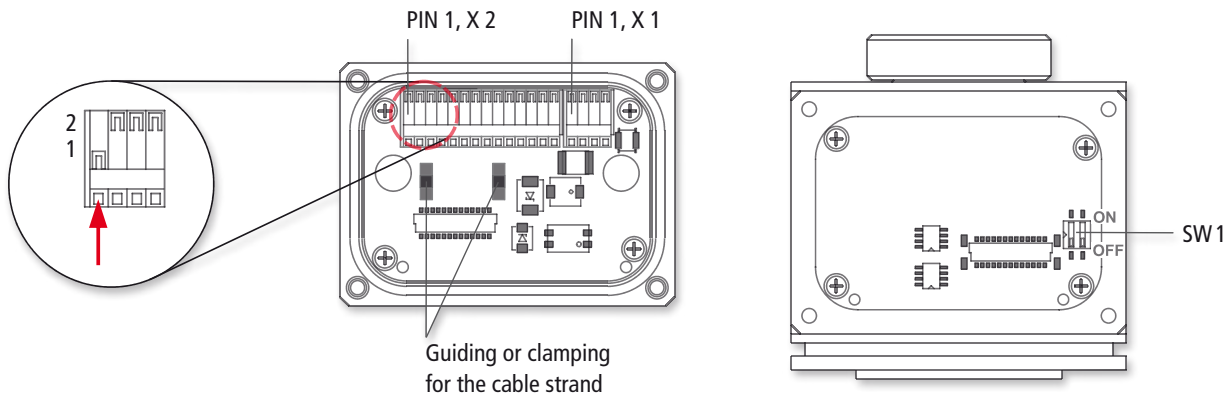

- _bring locking slide into position „1“
- _insert strand
- _bring locking slide into position „2“ and lock

X1, voltage supply

PIN	Signal	Description	
1	+ 24 V DC (11 ... 28 V DC)	Voltage supply	PIN 1/2 wired through
2	+ 24 V DC (11 ... 28 V DC)	Voltage supply	
3	0 V	GND	PIN 3/4 wired through
4	0 V	GND	

Attention! Out of safety reasons the GND (PIN 3/4) has to be wired with two different channels!

X2, measurement system

PIN	Signal	Description
1	N.C.	Do not connect!
2	Cosine – / optional channel A –	1 Vss, differential / differential RS 422
3	Cosine + / optional channel A +	1 Vss, differential / differential RS 422
4	N.C.	Do not connect!
5	Sine – / optional channel B –	1 Vss, differential / differential RS 422
6	Sine + / optional channel B +	1 Vss, differential / differential RS 422
7	Main system SSI-Data_OUT –	Data –, main system, differential RS 422
8	Main system SSI-Data_OUT +	Data +, main system, differential RS 422
9	Main system SSI-Clock_IN –	Clock –, main system, differential RS 422
10	Main system SSI-Clock_IN +	Clock +, main system, differential RS 422
11	Safety system SSI-Data_OUT –	Data –, safety system, differential RS 422
12	Safety system SSI-Data_OUT +	Data +, safety system, differential RS 422
13	Safety system SSI-Clock_IN –	Clock –, safety system, differential RS 422
14	Safety system SSI-Clock_IN +	Clock +, safety system, differential RS 422

TR-Electronic – Your Partner in Automation



Programmable rotary encoder

The standard of automation technology, available with all current fieldbus systems: PROFIBUS, Interbus, CANopen, DeviceNet and Industrial Ethernet. Including TR-Electronic's variety of mechanics, interfaces and functions.



Incremental rotary encoder

From 24 mm external diameter up to 55 mm hollow shaft – we always have a solution!

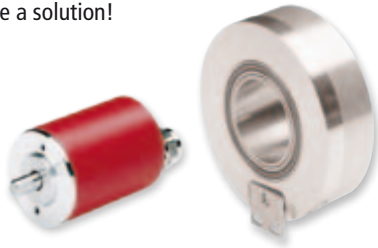

Motor feedback systems

Feedback encoder for modern positioning drives. Optional integrated or directly mounted on the drive shaft via hollow shaft.



Linear absolute displacement sensors

The compact class for linear absolute measurement. Directly bus-ready, suitable for harsh environmental conditions and for installation in hydraulic cylinders.



Absolute high resolution linear measurement systems

Linear measurement with absolute sub-micron resolution without referencing.

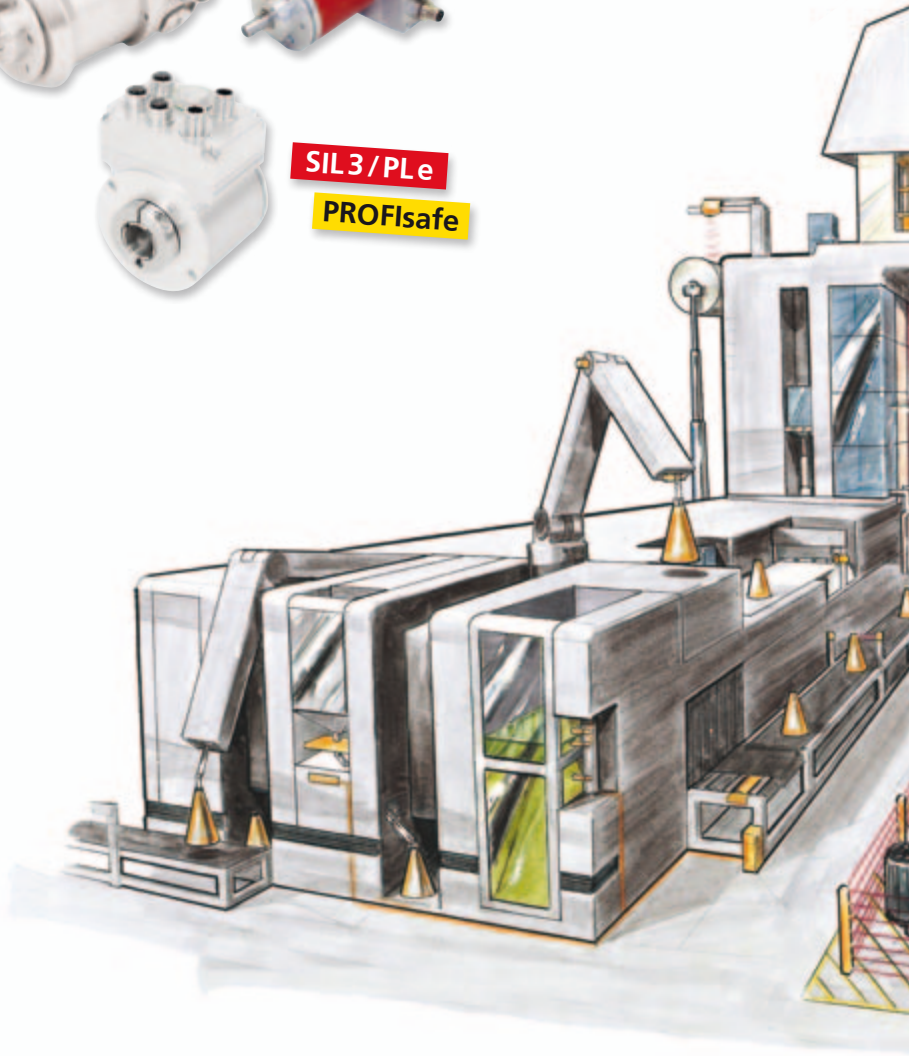

General/Definition

CD_75 M

PROFIsafe

2 x SSI with checksum

Intelligent positioning drive

Absolute positioning directly via fieldbus. Integrated motor, power electronics, closed loop controller, absolute encoder, PLC functions and fieldbus interface.

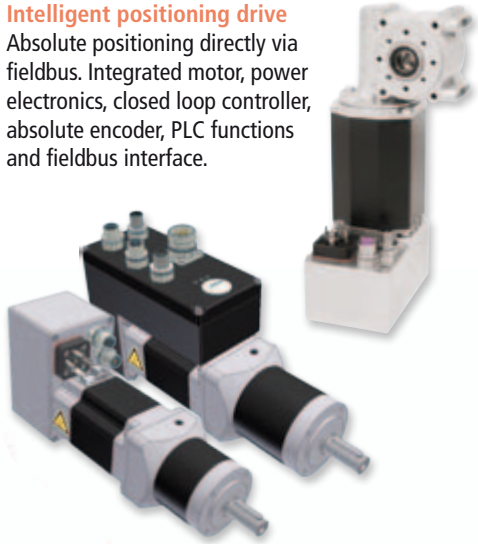

Heavy-duty industrial PC

Double shock proof mounted housing isolates the electronics from vibration, while front access (MIPC) simplifies configuration and start up. Choose from our wide selection of housings.

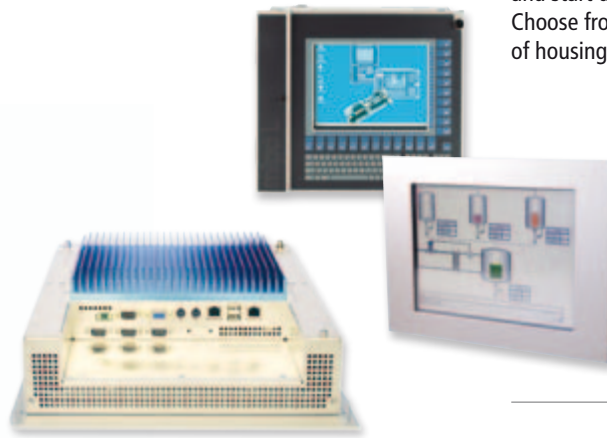

SPC – the PLC for PC

Turns every PC into an efficient PLC under S5/S7 or IEC 1131 protocols. Combines the comfort of PC control with the safety of a separate processor for PLC tasks.



@ctivelO – more than fieldbus modules

Modular, rugged fieldbus node system I/O-node, small-scale PLC, decentralized axis controller, high performance cam controller, DIN-rail mounted industrial PC, servo controller for the hydraulic ... with commercial fieldbus systems, such as Profibus-DP, CANopen, DeviceNet, LightBus ... and ETH-ERNET as option!



Laser distance measuring systems

Absolute and wear-free measurement of distances up to 200 m via SSI, fieldbus and Ethernet.

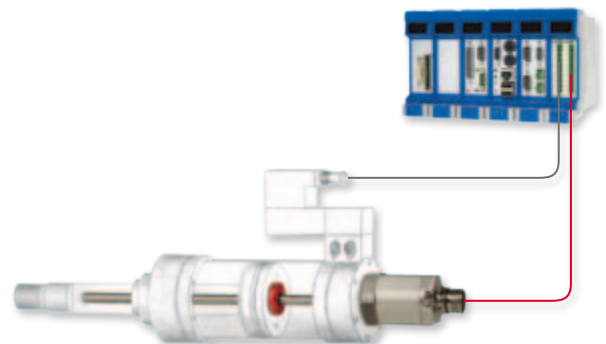

Headquarter

TR-Electronic GmbH
Eglshalde 6
D-78647 Trossingen
Germany

Tel.: +49/7425 228-0
Fax: +49/7425 228-33
info@tr-electronic.de
www.tr-electronic.de

International

Argentina

AEA Aparatos Eléctricos Automáticos
S.A.C.I.E./Asunción 2130
AR-1419 Buenos Aires
Tel.: +54/11 - 4574 1155
Fax: +54/11 - 4574 2400
servicioalcliente@aea.com.ar
www.aea.com.ar

Australia

Sensor Measurement Pty Ltd.
Unit 8/26 Shields Crescent
P.O. Box 1079
AU-Booragoon
Western Australia 6154
Tel.: +61/8-93 17 25 52
Fax: +61/8-93 17 24 52
sales@
sensormeasurement.com.au
www.sensormeasurement.com.au

Austria

TR-Electronic GmbH
Tragösserstraße 117
A-8600 Bruck/Mur
Tel.: +43/38 62-5 50 06 0
Fax: +43/38 62-5 50 06 33
info@tr-electronic.at
www.tr-electronic.at

Belgium

Martek SPRL - BVBA
Rue du Broux 16
B-1320 Beauvechain
Tel.: +32/10 86 82 80
Fax: +32/10 86 82 89
info@martek.be
www.martek.be

Brazil

Grupo C+ Tecnologia
Rua dos Caetés
601 - Perdizes
BR - São Paulo - SP
CEP-05016-081
Tel.: +55/11-2168 6554
Fax: +55/11-2168 6555
info@ctecnologia.com.br
www.ctecnologia.com.br

Canada

TR Electronic
P.O. Box 2543, Station B
CDN-London, Ontario Canada
N6A 4G9
Tel.: +1/519-452 1999
Fax: +1/519-452 1177
customercare@trelectronic.com
www.trelectronic.com

China

TR-Electronic (Beijing) CO., LTD.
Rm. 1302, Side A, Lucky Tower
No. 3 Dongsanhuan North Road
Chaoyang District
CN-100027 Beijing, P.R. China
Tel.: +86/10 - 646 131 96
Fax: +86/10 - 646 135 51
lu.yu@tr-electronic.de
www.tr-electronic.cn

Czech Republic, Slovakia

DEL a.s.
Strojírenská 38
CZ-59101 Ždár nad Sázavou
Tel.: +420/566 657 100
Fax: +420/566 621 657
del@del.cz
www.del.cz

Denmark

TR-Electronic Danmark ApS
Hustedgårdvej 22
DK-8722 Hedensted
Tel.: +45/75 89 06 03
Fax: +45/75 89 06 36
cbj@tr-electronic.dk
www.tr-electronic.dk

Finland

Sarlin Oy Ab
P.O. Box 750
FI-00101 Helsinki
Tel.: +358/10 - 550 4000
Fax: +358/10 - 550 4201
info@sarlin.com
www.sarlin.com

France

TR-Electronic France SARL
1 Av. Christian Doppler
Bâtiment 2
F-77700 Serris
Tel.: +33/1-64 63 68 68
Fax: +33/1-61 10 17 66
info@tr-electronic.fr
www.tr-electronic.fr

Great Britain

TR-Electronic Limited
12a Oak Industrial Park
Great Dunmow
GB-Essex CM6 1XN
Tel.: +44/1 371-876 187
Fax: +44/1 371-876 287
info@tr-electronic.co.uk
www.tr-electronic.co.uk

India

Global-Tech (India) Pvt Ltd
404 White House
1482 Sadashiv Peth
IND-Tilak Road, Pune - 411 030
Tel.: +91/20- 2447 00 85
Fax: +91/20- 2447 00 86
info@globaltechindia.com
www.globaltechindia.com

Israel

DOR Drive Systems L.T.D.
P.O.Box 6
ISR-49910 Kibbutz Einat
Tel.: +972/3 9007595
Fax: +972/3 9007599
sales@dor1.co.il
www.dor1.co.il

Italy

Telestar S.r.l.
Via C. Colombo 13
I-22069 Rovellasca (Co)
Tel.: +39/02-96 74 02 68
Fax: +39/02-96 74 02 73
telestar@telestar-automation.it
www.telestar-automation.it

Japan

SANTEST CO. LTD.
1-60 Tsuneyoshi, 1-Chome
Konohanaku
J-Osaka 554-8691
Tel.: +81/6-6465 5561
Fax: +81/6-6465 5921
info@santest.co.jp
www.santest.co.jp

Mexico

TR Electronic
P.O. Box 2543, Station B
CDN-London, Ontario Canada
N6A 4G9
Tel.: +1/519-452 1999
Fax: +1/519-452 1177
customercare@trelectronic.com
www.trelectronic.com

Netherland

TR-Electronic Nederland BV
Postbus 1682
NL-6201 BR Maastricht
Tel.: +31/43 352 3614
Fax: +31/43 352 3555
info@tr-electronic.nl
www.tr-electronic.nl

Norway

TR Electronic Norway AS
Fusdal Terrasse 3
N-1387 Asker
Tel.: +46 708 696 533
Fax: +46 875 676 80
E-Mail: info@trelectronic.no
Homepage: www.trelectronic.no

Poland

Stoltronic-Polska Sp. z o.o.
ul. Dabrowskiego 238C
PL - 93-231 Lodz
Tel.: +48/42-649 12 15
Fax: +48/42-649 11 08
stoltronic@stoltronic.pl
www.stoltronic.pl

Singapore

Globaltec Electronics (Far East)
Pte. Ltd.
50 Bukit Batok Street 23
#06-27 Midview Building
SIN-659578 Singapore
Tel.: +65/6267 9188
Fax: +65/6267 8011
info@globaltec.com.sg
www.globaltec.com.sg

Slovenia

S.M.M. d.o.o.
Jaskova 18
SI-2001 Maribor
Tel.: +386/2450 2300
Fax: +386/2450 2302
smm@siol.net
www.smm.si

South Africa

Angstrom Engineering (Pty) Ltd.
19 Tom Muller Road
P.O. Box 793
SA-Meyerton 1960
Tel.: +27/16 3620300
Fax: +27/16 3620725
info@angstromeng.co.za
www.angstromeng.co.za

South Korea

MS Intech Co., Ltd.
B-306, Gasan Digital 1 Ro 119
Keumcheon-Gu
KOR-Seoul
Tel.: +82/2-334 0577
Fax: +82/2-862 1591
sales@msintech.com
www.msintech.com

Spain, Portugal

Intertronic Internacional, SL
C/Johannes Gutenberg, 4 y 6
P.I. Parque Tecnológico
E-46980 Valencia
Tel.: +34/96-375 8050
Fax: +34/96-375 1022
info@intertronic.es
www.intertronic.es

Sweden

TR Electronic Sweden AB
Enebybergsvägen 10B
S-182 36 Danderyd
Tel.: +46/8-756 72 20
Fax: +46/8-756 76 80
mailbox@trelectronic.se
www.trelectronic.se

Switzerland

TR-Electronic SA
14, Ch. Pré-Fleuri
CH-1228 Plan-les-Ouates/Genève
Tel.: +41/22-7 94 21 50
Fax: +41/22-7 94 21 71
info@tr-electronic.ch
www.tr-electronic.ch

Taiwan

Asia Jyujiang Enterprise Co., Ltd.
5F., No. 456, Minguan 2nd.
Qianzhen Dist.
Kaohsiung City 80654
Taiwan (R.O.C.)
Tel.: +886/7-3385067
Fax: +886/7-3380271
asiataiwan@seed.net.tw

Thailand

T+R Electronic (Thailand) Co.,
Ltd.
120/62 Moo 8 Bang Sare
TH - Sattahip, Chonburi 20250
Tel.: +66/38 737 487
Fax: +66/38 737 171
trthailand@trelectronic.co.th
www.trelectronic.co.th

Turkey

Üniversa İç-Dis Tic. ve
Mak. San. Ltd. Sti.
Cemal Gürsel Caddesi
No: 11 D: 4
TR-35600 Karsiyaka-IZMIR
Tel.: +90/232 382 23 14
Fax: +90/232 382 23 24
info@universa.com.tr
www.universa.com.tr

USA (TR-Electronic)

TR Electronic
P.O. Box 4448
US-Troy, MI 48099
Tel.: +1/248-244-2280
Fax: +1/248-244-2283
customercare@trelectronic.com
www.trelectronic.com

USA (TRsystems)

TRS Fieldbus Systems, Inc.
666 Baldwin Court
US-Birmingham, MI 48009
Tel.: +1/586 826-9696
Fax: +1/586 826-9697
support@trs-fieldbus.com
www.trs-fieldbus.com

Eastern Europe, CIS

Stoltronic Handels GmbH
Karl-Kurz Gasse 21
A-2482 Münchendorf
Tel.: +43/2259 30133
Fax: +43/2259 30149
stoltronic@aon.at



Copyright by TR-Electronic. All rights reserved · 68-105-098 · TR-V-PR-GB-0008-01 · February 2013.

TR-Electronic GmbH
Eglishalde 6
D-78647 Trossingen

Tel. +49 (0)7425/228-0
Fax +49 (0)7425/228-33
info@tr-electronic.de

www.tr-electronic.de